

O-L85-XXXXXXXXXX-X
Ultra Low Phase Noise, Precision SC-cut HF OCXO
in Miniature 15x21x11 mm DIL14 Compatible
Package

Rev. C

Product Data Sheet

Features

- Ultra Low Power Consumption
- SC-cut crystal
- Ultra Low Phase Noise
- Sine Wave +13 dBm output
- Extremely Small Hermetic Package

Applications

- Instrumentation
- Radar
- High End Synthesizers
- Battery powered equipment
- Communications

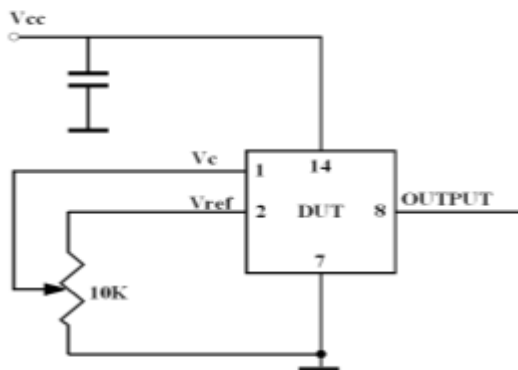
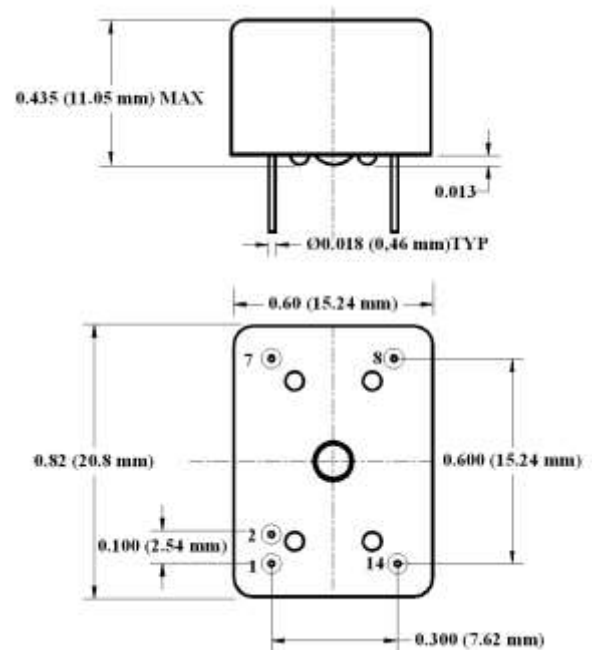

O-L85-XXXXXXXXXX-X

Rev. C

Parameter	Symb	Condition	Min	Typ	Max	Unit	Note
Absolute Maximum Ratings							
Input Break Down Voltage	Vcc		-0.5		6.5	V	Vcc option 0 Vcc option A
Storage temper.	Ts		-55		85	°C	
Control Voltage	Vc		-1		10.5	V	

Electrical (1)

Frequency	F		30		125	MHz		All parameters for 100,000 MHz	
Frequency stability	$\Delta F/F$	vs. Temp.		± 50		ppb	See table below Note 2		
		vs. Supply			2	ppb/5% change			
		Vs. load			2	ppb/5% change			
Aging		per day per first year 10 years		3E-9 3E-7	1.5	ppm	After 30 days of continuous operation		
Allan Deviation		.01s to 1s		5E-11					
SSB Phase Noise at 100.000 MHz 5*	$L(\Delta f)$	10 Hz		-95			dBc/Hz		Grade "L"
		100 Hz			-125				
		1 KHz			-158				
		10 KHz			-170				Grade "P"
		100 KHz			-178				
		10 Hz		-100					
		100 Hz			-130				
		1 KHz			-160				
		10 KHz			-172				
100 KHz			-178						
10 Hz		-105				Grade "U", Available with slope option "L"			
100 Hz			-135						
1 KHz			-162						
10 KHz			-175						
100 KHz			-178						
Retrace		After 30 minutes		± 20		ppb			
G-sensitivity		worst direction			± 0.5	ppb/G			
Input Voltage	Vcc		4.75 3.165	5.0 3.30	5.25 3.465	V	See chart below to specify		
Power consumption Still air 6*, 100 MHz	P	steady state, 25°C operating temp range to 70°C start-up		0.5 0.4 0.3 1.2	0.6 0.5 0.35 1.5	W	Grade "N" Grade "A" Grade "X"		
Spectral Purity		Subharmonics Spurious Harmonics		none -35	-80 -30	dBc			
Load		10KOhm//15pF (HCMOS/TTL), AC-coupled 50 Ohm (Sine-wave)					Output Code T Output Code S		
Warm-up time		τ				to 0.20ppm accuracy to 0.35ppm			
Output Power			+10		90 60	seconds			
Logic 1 (CMOS)	Voh		0.7 Vref	+13		dBm	100 MHz, Output Code S		
Logic 0 (CMOS)	Vol					V	Output Code T		



Reference Voltage	Vref				0.1 Vref	V	Output Code T
Output Impedance at Vref	Rref			4.5 3.0		V	5 V supply 3.3 V supply
Control voltage	Vc		0 0	100		Ohm	
Input Impedance	Zin	At Vc Pin	10		10.0 4.5	V	Slope option "L" Slope option "P"
Pull range		from nominal F				KOhm	
Absolute pull range	APR		±0.5	±2.5		ppm	
Deviation slope		Monotonic, posit				ppm	
Linearity			±10%	0.7 1.3		ppm/V	Slope option "L" Slope option "P"
Setability	Vc0	@25°C, Fnom.	4.0 1.75				
Modulation Bandwidth	Fm		DC	5.0 2.25	6.0 2.75	V	Slope option "L", no bias Slope option "P"

Environmental and Mechanical

Operating temp. range	0 to 70°C Standard, Other options – see Chart below
Mechanical Shock	Per MIL-STD-202, 30G, 11ms
Thermal Shock	Per MIL-STD-883, Method 1011, Condition A
Vibration	Per MIL-STD-202, 5G to 2000 Hz
Operational vibration	Phase noise under vibration to be verified by the customer
Seal	Hermetically sealed
Soldering Conditions	260°C for 10 seconds MAX, leads only

Electrical Connections

Pin Out	Pin #1- Vc; Pin #2 – Vref ; Pin#7 – Case, GND; Pin #8 – OUTPUT; Pin #14 - Vcc
----------------	---



Creating a Part Number

O **L** **85** - **X** **X** **XX** **X** **XX** **X** **X** - **X** - Frequency, MHz

OCXO

Low Power

Package Code

85- DIL14 through hole 5 pin

Supply Voltage

Code	Specification
0	5.0V ±5%
A	3.3V ±0.15 V

Output

Code	Specification
S	Sinewave
T	CMOS/TTL

Temperature Stability

Code	Specification
17	1x10 ⁻⁷
58	5x10 ⁻⁸
YZ	Yx10 ^{-Z}

Slope Option

Code	Spec
P	0 - 4.5 V
L	0 -10 V

Environmental

Code	Specification
L	Contains a level of lead that is in excess of RoHS directive
R	RoHS compliant

Power Consumption

Code	Specification
N	Standard
A	Low
X	Lowest

Phase Noise Grade (see table)

Code	Specification
L	Standard
P	Premium
U	Ultimate

Temperature Range

Code	In 5°C steps **
First letter	Lowest temperature from A = -40°C
Second letter	Highest temperature to Z = 85°C
Examples	
IS	0°C to 50°C
GU	-10°C to 60°C
EW	-20°C to 70°C

**Temperature Code Table

Letter	Temp °C	Letter	Temp °C	Letter	Temp °C	Letter	Temp °C	Letter	Temp °C	Letter	Temp °C
A	-40	F	-15	K	10	P	35	U	60	Z	85
B	-35	G	-10	L	15	Q	40	V	65		
C	-30	H	-5	M	20	R	45	W	70		
D	-25	I	0	N	25	S	50	X	75		
E	-20	J	5	O	30	T	55	Y	80		

Notes:

1. Not all combinations are available – consult factory
2. It's not recommended to over-specify stability over temperature performance: it significantly affects the cost.
3. Unless absolutely necessary do not specify highest operating temperature above 70°C
4. All parameters, unless otherwise specified, are at nominal conditions, ie: T=25°C, Nominal Vcc & Nominal Load.
5. Specifications for Vcc= 5.0 V. At Vcc = 3.3 V phase noise may slightly deteriorate from those values. Close to the carrier phase noise deteriorates with increase in frequency.
6. Power consumption listed in the table is for 100.000 MHz, sine-wave output. With increase in upper operating temperature, the power consumption will increase about 15 to 30 mW per 5°C depending on the grade.

NOISE XT

Phase Noise Plot

